

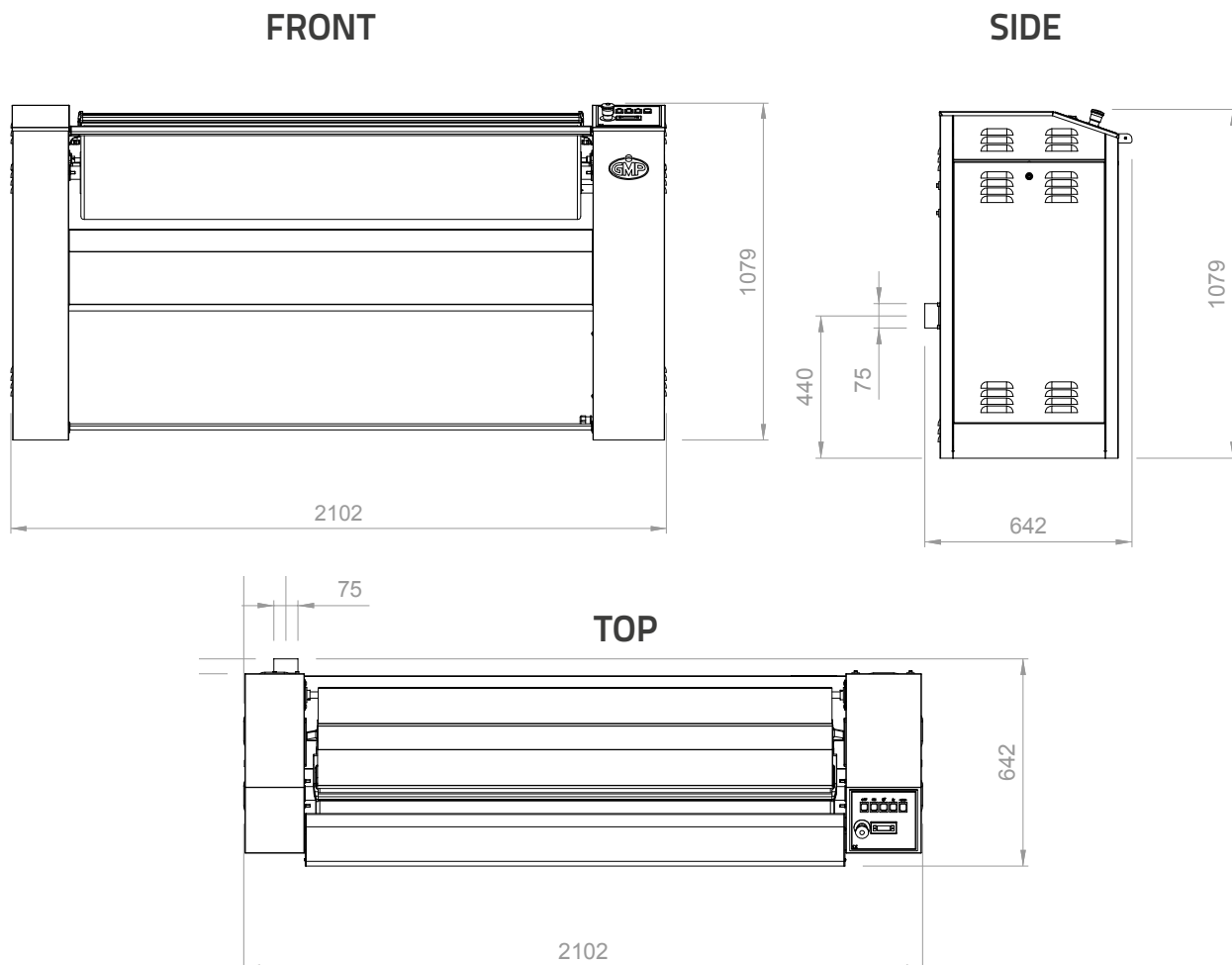



# GMP 160.30 - GMP 160.30.A - GMP 160.30.VAR

## INSTALLATION PLAN



## WHAT YOU NEED

Electrical cable + industrial plug			
	V.230/1/50-60Hz	V.230/3/50-60Hz	V.400/3N/50-60Hz
	n/a	36,5 Amps	21,5 Amps
Total power required	n/a	12,5 kW	12,5 kW
Differential magnetothermal switch	n/a	I <sub>dn</sub> = 0.03 Amps	I <sub>dn</sub> = 0.03 Amps
Ducting	n/a	optional Ø75 mm, 90 m <sup>3</sup> /h	optional Ø75 mm, 90 m <sup>3</sup> /h
Clearance around the ironer	back: 400 mm - right: 650 mm - left: not needed		