

# 300/350 TS K

# 300/350 TC K



**300/350 TS K**



**300/350 TC K**

## AFFETTATRICE VERTICALE

- Costruita in lega di alluminio trattata con ossidazione anodica.
- Trasmissione a cinghia Poly V.
- Affilatoio incorporato.
- Per il dettaglio e la ristorazione collettiva.
- Comandi con dispositivo N.V.R.

## VERTICAL SLICING MACHINE

- Made of aluminium alloy treated with anodic oxidation.
- Poly V belt drive.
- Built-in sharpener.
- For retail and collective catering.
- Controls with N.V.R. device

## TRANCHEUSE VERTICALE

- Réalisées en alliage d'aluminium traité par oxydation anodique.
- Transmission à courroie Poly V.
- Aiguiser incorporé.
- Pour le détail et la restauration collective.
- Boutons Marche-Arrêt.

## VERTIKALE AUFSCHNITTMASCHINE

- Ausgeführt aus Aluminiumlegierung, poliert und eloxiert.
- Riemenantrieb Poly V.
- Eingebaute Schleifvorrichtung.
- Für Lebensmitteleinzelhandel und Großgastronomie.
- Ein-Aus Drucktaste.

## CORTADORA DE FIAMBRES VERTICALES

- Costruita en aleación de aluminio tratada con oxidación anódica
- Transmisión a correa Poly V.
- Afilador incorporado.
- Para supermercados, hipermercados, centros de envasado, venta minorista de alimentos y restauración colectiva.
- Mandos con dispositivo N.V.R.



## CARATTERISTICHE TECNICHE - TECHNICAL SPECIFICATIONS - TECHNISCHE DATEN - CARACTÉRISTIQUES - ESPECIFICACIONES

		300 TS K	300 TC K	350 TS K	350 TC K
diametro lama, diameter of the blade, diamètre de la lame, Klingendurchmesser, diametro de la cuchilla	mm	300	300	350	350
motore TF, motor TPH, moteur TPH, Motor DPH, motor TF	kW (HP)	0,26 (0,35)	0,26 (0,35)	0,26 (0,35)	0,26 (0,35)
motore MF, motor SPH, moteur MPH, Motor EPH, motor MF	kW (HP)	0,19 (0,25)	0,19 (0,25)	0,19 (0,25)	0,19 (0,25)
corsa carrello, carriage Stroke, course du chariot, Schilittenweglauf, carrera del carro	mm	300	300	300	300
ampiezza taglio, cut, ampleur de coupe, Schnittgröße, amplitud de corte	mm Ø	222	230	243	250
spessore taglio, cut thickness, épaisseur de coupe, Schnittstärke, espesor de corte	mm	0/15	0/15	0/15	0/15
peso netto, net weight, poids net, Nettogewicht, peso neto	kg	28	27	29	28

	A	B	C	D	E	F	G	H
300 TS K	495	343	594	706	767	503	692	548
350 TS K	495	343	594	706	767	528	692	548

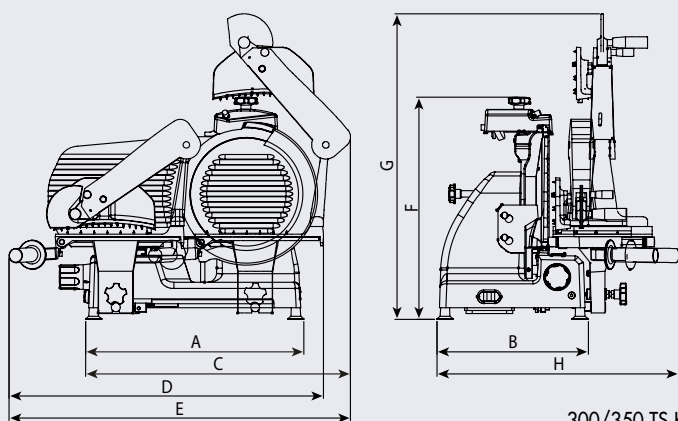

300/350 TS K

	A	B	C	D	E	F	G
300 TC K	495	343	629	666	760	629	503
350 TC K	495	343	608	660	754	629	529

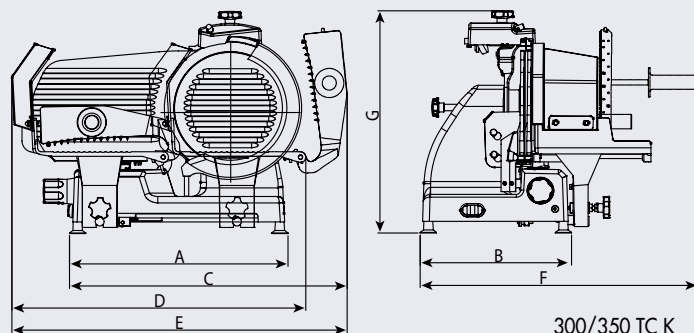

300/350 TC K



Macchina conforme alle norme CE in materia di igiene e di sicurezza.

The machine complies with CE standards in terms of hygiene and safety.