

APRIBOX

Automatic can opener



CAN OPENING MADE EASY

The traditional way of opening cans is time consuming, is usually unsafe and requires the can to be held with one hand while using the other hand to operate the opener. For large numbers these disadvantages become very acute.

APRIBOX removes these hazards and reduces costs. Once the can has been fitted into the cutting position no other direct manual intervention is required, the machine automatically locks on to the can and turns it at the same time as it cuts.

APRIBOX has a rotary cutting system which is fast and precise which:

- Leaves no sharp edges;
- Allows an adjustment to the height of the cut;
- Deals with circular cans weighing up to 5 Kg.

APRIBOX is an easily operated, indispensable tool eliminating risk and saving valuable time.

Wilma

LA SCIENZA DELLE GRANDI CUCINE

APRIBOX

Automatic Can Opener



FEATURES

DESIGN FEATURES

- Supporting column, locking clamp and fastening plate to the working surface, made of 18/10 stainless steel.
- Cutting blade protection made of 18/10 stainless steel.
- Can drive gear and cutting blade made of hardened steel.

SPECIFICATIONS

- Can rotation device.
- Can incision device.
- Height of cut adjusting device.
- Magnetic device for seizing and extracting the cut lid.
- Geared motor unit, kW 0,12-230.1.50+E, protected in a special plastic case.
- Weight 10 kg.

DIMENSIONS

- Width 140 mm
- Length 470 mm
- Height 720 mm

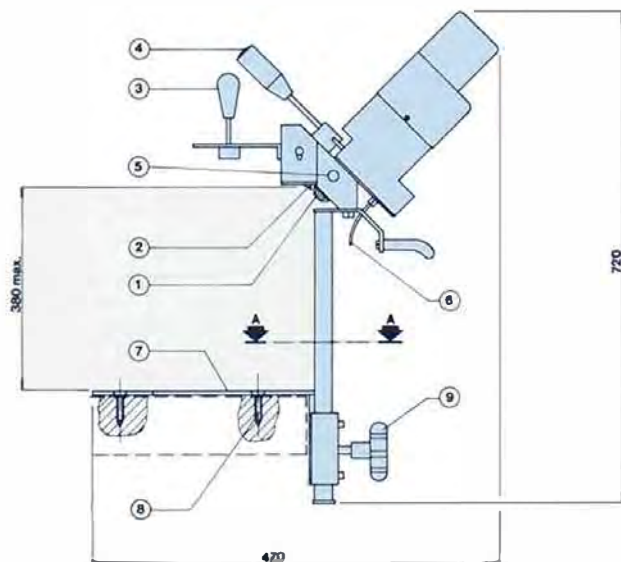

Sez. A-A

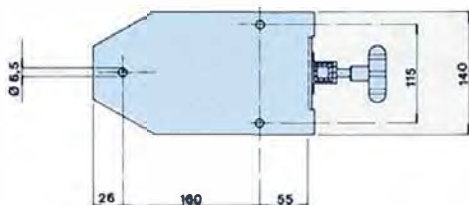

KEY

- 1) Drive gear. 2) Cutting blade. 3) Magnet supporting lever. 4) Cutting blade starting lever. 5) Lubricator . 6) Feeding cable. 7) Fastening plate. 8) Fastening screws. 9) Locking knob.

This pamphlet may not be reproduced either in full or in part - May 2004



DESIGNED AND MANUFACTURED
TO CE STANDARD

Company with UNI EN ISO 9001:2008
certified Quality System

Wilma

LA SCIENZA DELLE GRANDI CUCINE